

## VOX-065-TS

with VDX2-6526 / VDX3-6726

### FEATURES

- 6.5" TFT LCD with Resistive Touchscreen
- VDX2-6526 (800MHz) / VDX3-6726 (1GHz)
- 512MB / 1GB / 2GB System Memory Onboard
- Fanless and Low Power Consumption
- Metal Chassis
- SATA Support



### SPECIFICATION

LCD Display	Type	VGA TFT LCD
	Size	6.5"
	Resolution (Pixel)	640(W) x 480(H)
	Colors	262,144
	View Angle	Vertical 140° / Horizontal 160°
	Brightness	800 cd/m2
	Backlight Life	50,000 hrs
	Contrast Ratio	600 : 1
CPU	DM&P VortexDX2-800MHz / Vortex86DX3-1GHz	
Cache	L1: 16KB I- Cache, 16KB D- Cache / L2: 256KB Cache	
Memory	512MB / 1GB / 2GB Memory Onboard	
Watchdog Timer	Software Programmable from 30.5u to 512 Seconds x 2 Sets	
Serial Port	RS-232 / 485 x 4	
USB Ports	USB Ports (Version 2.0) x 4	
Ethernet	Integrated 10/100M Ethernet & Giga Ethernet x 2	
Audio	HD Audio-Realtek ALC262 CODEC	
Internal Drives	SATA Support	
Touch Screen Type	Analog Resistive	
Bus Interface	PC/104 Standard Compliant	
Power Requirement	+5VDC , +12VDC	
Power Consumption	47W	
Operating Temperature	0~+50°C (32~+122°F) / -20~+60°C (-4~+140°F)	
Storage Temperature	-30~ +70°C (-22 ~+158°F)	
Operating Humidity	0% ~ 90% Relative Humidity, Non-Condensing	
Operating System	DOS, Linux, Win CE, Win XP, Win 7, Windows Embedded Standard	
Dimensions	190x145x41.9mm (7.48x5.71x1.65 inches)	
Weight	822g	

## DIMENSIONS

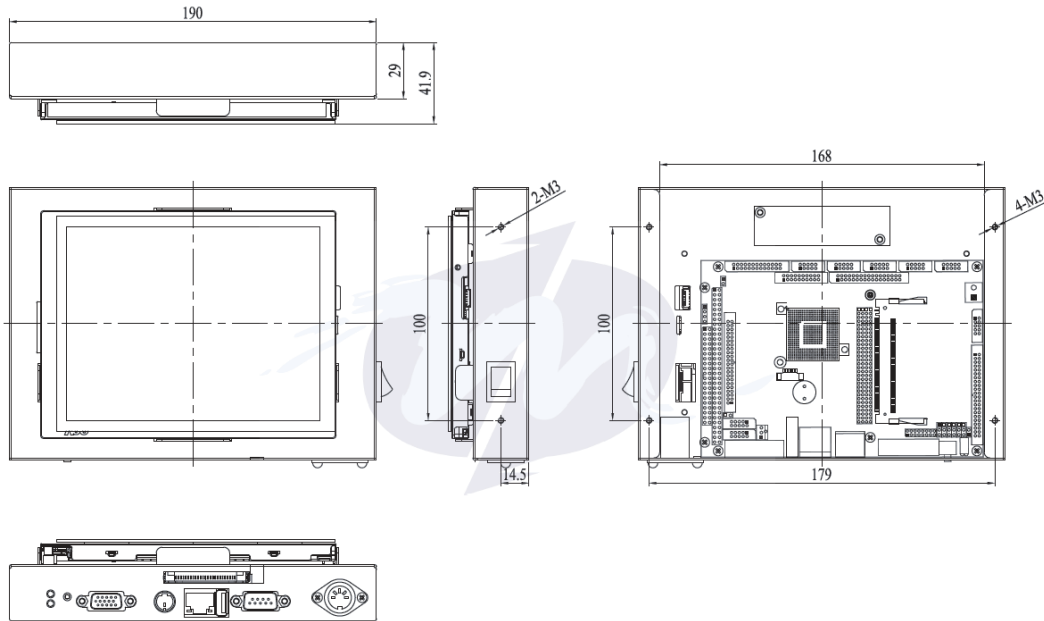

Unit: mm

## I/O Overview

### VOX-065-TS Right Side

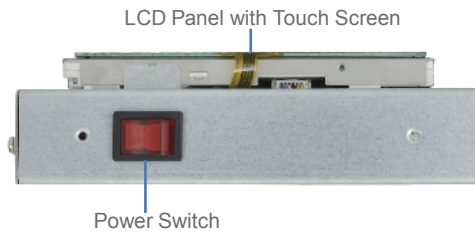

### VOX-065-TS Bottom Side

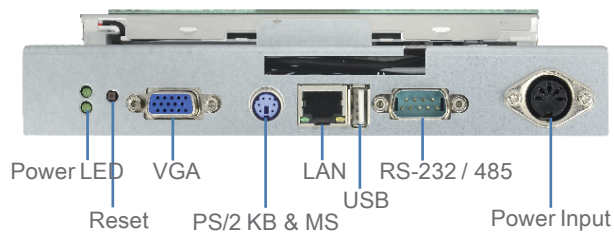

### VOX-065-TS Rear Side

