

# WLP-7A20-17V

## 17" Core i Fanless Industrial Panel PC



### Key Features

- Fanless industrial panel PC w/ reliable thermal design
- Intel 3rd Generation (Ivy Bridge) Core i5/i7 CPU
- 17" 5:4 SXGA 1280x1024 380 nits LCD w/ CCFL backlight
- Resistive touch and front IP66 panel mount housing
- Two mini PCIe sockets for WLAN & other add-on expansions
- Robust metal housing and HDD anti-vibration design
- Flexible customization for specific application requests

### Storage

**HDD** 2.5" SATA HDD drive bay x 1 + anti-vibration kit, 320GB / 500GB  
**Expansion slot** Mini PCIe x 2 (52 pin card-edge type)

### I/O & Control Keys

**USB** USB 2.0 x 4  
**COM** DB-9 x 3 (RS232 x 2, RS232/422/485 <w/ auto flow control>)  
**LAN** RJ-45 x 2 ,Gigabit  
**Audio** Line-out, Microphone-in (3.5 mm phone-jack)  
**Video-out** DVI-I x 1  
**Power input** DC-in x 1, 6V~32V  
**Control keys** · Rear bottom: Power on/off, reset  
· Brightness adjustment through Wincomm's SW utility  
**LED indicator** Front: Green – power on / Amber – HDD accessing

### Power

**Power adaptor** External, 80 watts, 90~264V AC in, 12V DC out, 1.2m DC cable  
**Power consumption** 60 watts (typical, without any add-ons)

### Mechanical & Environmental

**Housing** · Standard: Panel mount  
· Customization: Open frame & chassis  
**Housing materials** · SECC metal housing (black color)  
· Panel mount bezel: Aluminum (black or silver), optional stainless steel  
**IP rating** IP66 – front side (for panel mount housing)  
**Cooling** Fanless w/ internal heat sink / pipe & external aluminum fin plate  
**Mounting** VESA 75 x 75 / 100 x 100 mm  
**Dimension** 426.2 x 358.6 x 90 mm (W x H x D)  
**Weight (net)** 8.5 Kg (approximate, w/o power adaptor)  
**Temperature** · Operating - 0°C~50°C (w/ air flow) /  
- 0°C~40°C (no air flow)  
· Storage - -20°C~60°C  
**Humidity** Operating & storage – 10%~90%, non-condensing  
**Regulatory** FCC-A, CE(EMC), VCCI, UL

### Main System

**CPU** · Intel Core i5-3317U 1.7GHz (Dual Core, 3MB cache)  
· Intel Core i7-3517U 1.9GHz (Dual Core, 4MB cache)  
· Intel Core i3-3217U 1.8GHz (Dual Core, 3MB cache)  
· Intel Celeron 847E 1.1GHz (Dual Core, 2MB cache)  
· Core i CPU w/ BGA1023 package and 17W TDP  
**Chipset** Intel® BD82HM65 PCH  
**Graphics** · Intel Core i7-3517U /Core i5-3317U /Core i3-3217U: Intel HD Graphics HD 4000  
· Celeron 847E: Intel HD Graphics  
**Memory** 8GB maximum, x 2 DDR3 SODIMM, 1066/1333MHz, 2GB/4GB/8GB  
**Serial ATA** SATA2 x 2, 300MB/s transfer rate  
**USB** x 7 (socket), USB 2.0 (x 4 external, x 3 internal)  
**COM** x 6 (x 2 external, x 4 internal)  
**Audio** Realtek ALC262 audio codec, 2+2 watts amplifier  
**LAN** Marvell 88E8071 Gigabit Ethernet x 2  
**BIOS** · AMI BIOS, 4M EEPROM  
· RTC wake up / Wake on LAN / Power on after power failure / PnP / ACPI

### LCD Panel

<b>Size</b>	17" 5:4
<b>Resolution (pixel)</b>	SXGA 1280 x 1024
<b>Brightness (cd/m2)</b>	380nit
<b>Contrast</b>	1000:1
<b>Number of Colors</b>	16.7M (6-bit x 3 + FRC)
<b>View Angle (H/V)</b>	170 (H) / 160 (V)
<b>Response time</b>	5 ms (R + F)
<b>Backlight /life time</b>	CCFL x 2, 50,000 hours life time

### Touch Panel

<b>Technology</b>	Resistive touch, 5-wire
<b>Light transmittance</b>	80±3%
<b>Hardness</b>	3H
<b>Touch stylus</b>	No limitation
<b>Resolution</b>	4096x4096
<b>Lifetime</b>	36 million activations

# WLP-7A20-17V

17" Core i Fanless Industrial Panel PC

## Outline Dimension

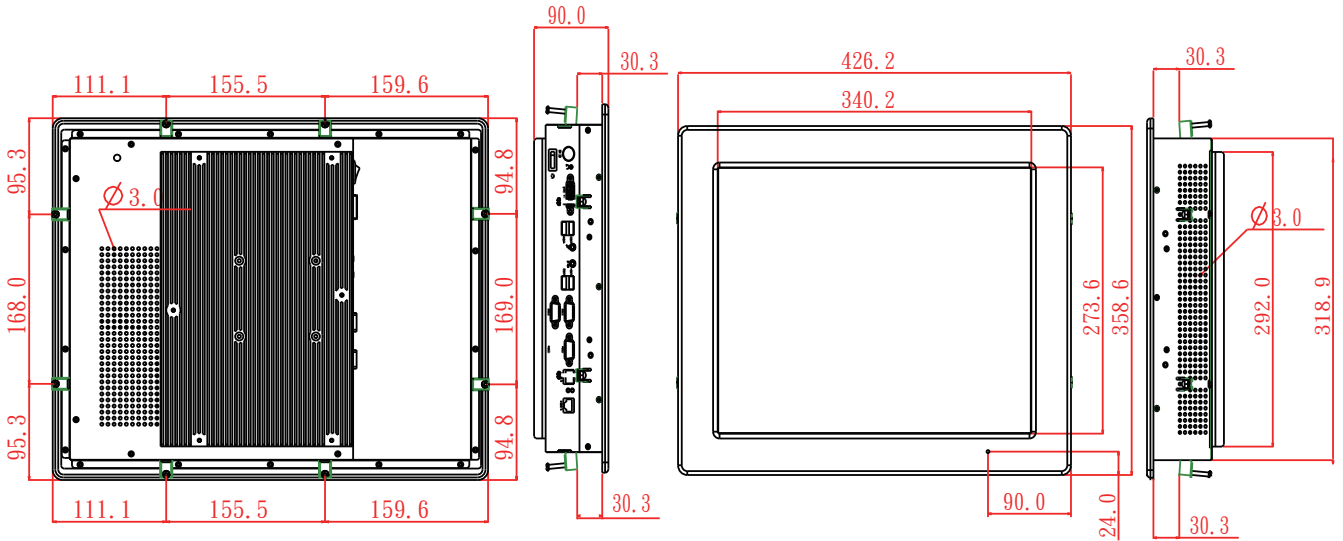

## I/O Connectors

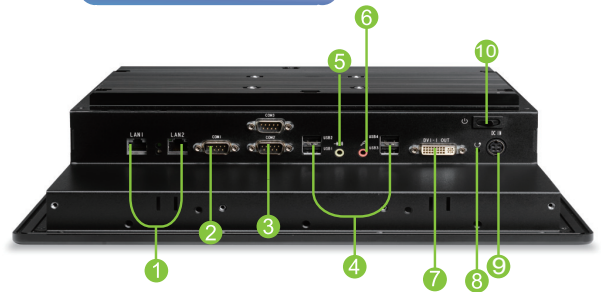

- |                 |                 |
|-----------------|-----------------|
| ① LAN x 2       | ⑥ Microphone-in |
| ② RS232/422/485 | ⑦ DVI-I         |
| ③ RS232 x 2     | ⑧ Reset         |
| ④ USB x 4       | ⑨ DC-in         |
| ⑤ Line out      | ⑩ Power on/off  |

## Packaging / Options / Customization

- Packaging** System, power adaptor, AC power cord, CD (drivers & manual)
- Options**
- . WLAN – 802.11 a/b/g/n mini PCIe module w/ external antenna x 1
  - . Stainless steel panel mount bezel
  - . Silver color panel mount bezel
  - . Change resistive touch to capacitive touch
- Customization**
- . Open frame housing
  - . Chassis type housing
  - . TPM module

## Ordering Information

- . CPU: Core i5 1.7G / Core i7 1.9G / Core i3 1.8G / Celeron 1.1G
- . Memory: 2G / 4G / 8G
- . HDD: None / 320G / 500G
- . Panel mount bezel: Black / Silver / Stainless steel
- . WLAN: None / x 1
- . Touch: Resistive / Capacitive