

# SPC-1209/1709

Full IP-65 Stainless Steel Chassis  
Fanless Touch Panel PC

## Quick Reference Guide

4<sup>th</sup> Ed – 21 April 2016

### Copyright Notice

Copyright © 2016 Avalue Technology Inc., ALL RIGHTS RESERVED.

## FCC Statement



THIS DEVICE COMPLIES WITH PART 15 FCC RULES. OPERATION IS SUBJECT TO THE FOLLOWING TWO CONDITIONS:

(1) THIS DEVICE MAY NOT CAUSE HARMFUL INTERFERENCE.

(2) THIS DEVICE MUST ACCEPT ANY INTERFERENCE RECEIVED INCLUDING INTERFERENCE THAT MAY CAUSE UNDESIRE OPERATION.

THIS EQUIPMENT HAS BEEN TESTED AND FOUND TO COMPLY WITH THE LIMITS FOR A CLASS "A" DIGITAL DEVICE, PURSUANT TO PART 15 OF THE FCC RULES.

THESE LIMITS ARE DESIGNED TO PROVIDE REASONABLE PROTECTION AGAINST HARMFUL INTERFERENCE WHEN THE EQUIPMENT IS OPERATED IN A COMMERCIAL ENVIRONMENT. THIS EQUIPMENT GENERATES, USES, AND CAN RADIATE RADIO FREQUENCY ENERGY AND, IF NOT INSTALLED AND USED IN ACCORDANCE WITH THE INSTRUCTION MANUAL, MAY CAUSE HARMFUL INTERFERENCE TO RADIO COMMUNICATIONS.

OPERATION OF THIS EQUIPMENT IN A RESIDENTIAL AREA IS LIKELY TO CAUSE HARMFUL INTERFERENCE IN WHICH CASE THE USER WILL BE REQUIRED TO CORRECT THE INTERFERENCE AT HIS OWN EXPENSE.

## A Message to the Customer

### ***Avalue Customer Services***

Each and every Avalue's product is built to the most exacting specifications to ensure reliable performance in the harsh and demanding conditions typical of industrial environments. Whether your new Avalue device is destined for the laboratory or the factory floor, you can be assured that your product will provide the reliability and ease of operation for which the name Avalue has come to be known.

Your satisfaction is our primary concern. Here is a guide to Avalue's customer services. To ensure you get the full benefit of our services, please follow the instructions below carefully.

### ***Technical Support***

We want you to get the maximum performance from your products. So if you run into technical difficulties, we are here to help. For the most frequently asked questions, you can easily find answers in your product documentation. These answers are normally a lot more detailed than the ones we can give over the phone. So please consult the user's manual first.

To receive the latest version of the user's manual; please visit our Web site at:

<http://www.avalue.com.tw/>

# Content

<b>1.</b>	<b>Getting Started .....</b>	<b>4</b>
1.1	Safety Precautions .....	4
1.2	Packing List.....	4
1.3	System Specifications .....	5
1.4	System Overview .....	7
1.4.1	SPC-1209 Rear View .....	7
1.4.2	SPC-1709 Rear View .....	7
1.5	System Dimensions .....	8
1.5.1	SPC-1209 Front, rear and side view .....	8
1.5.2	SPC-1709 Front, rear and side view .....	9
<b>2.</b>	<b>Hardware Configuration .....</b>	<b>10</b>
2.1	SPC-1209/1709 connector mapping .....	11
2.1.1	Waterproof DB-9 connector (COM) .....	11

# 1. Getting Started

## 1.1 Safety Precautions

### Warning!



Always completely disconnect the power cord from your chassis whenever you work with the hardware. Do not make connections while the power is on. Sensitive electronic components can be damaged by sudden power surges. Only experienced electronics personnel should open the PC chassis.

### Caution!



Always ground yourself to remove any static charge before touching the CPU card. Modern electronic devices are very sensitive to static electric charges. As a safety precaution, use a grounding wrist strap at all times. Place all electronic components in a static-dissipative surface or static-shielded bag when they are not in the chassis.

## 1.2 Packing List

- 1 x SPC-1209/1709 Panel PC
- 1 x DVD-ROM contains the followings:
  - User's Manual (this manual in PDF file)
  - Ethernet driver and utilities
  - VGA drivers and utilities
  - Audio drivers and utilities
  - Wi-Fi drivers and utilities
  - Touch controller drivers and utilities
- 1 x Power Adapter
- 1 x DC-in extended cable
- 1 x USB+LAN+COM External cable 2000cm (only for SPC-1209)



### Note:

User must use waterproof type connector and cable when connect to I/O ports including DC jack, RJ45, COM and USB port.







If any of the above items is damaged or missing, contact your retailer.

## 1.3 System Specifications

Panel 		
Model	<b>SPC-1209</b>	<b>SPC-1709</b>
LCD size	12.1", 4:3	17", 4:3
Display type	XGA	SXGA
Resolution	1024 x 768	1280 x 1024
Pixel pitch	0.240mm(H) x 0.240mm(V)	0.264mm(H) x 0.264mm(V)
Luminance	600 cd/m <sup>2</sup>	350 cd/m <sup>2</sup>
Contrast ratio	700	800
Viewing angle	70(U), 70(D), 80(L), 80(R)	80(U), 80(D), 85(L), 85(R )
Response time	16 ms	30 ms
Backlight	LED	
Touch type	5 Wires resistive	
Touch Light transmission	80	
Touch interface	USB	
System 		
Board	<b>EBM-BYT</b>	<b>EBM-BYT</b>
CPU	Onboard Intel® Atom Quad-Core E3845 1.91GHz with Integrated Chipset	
I/O Chipset	E/C IT8528E	
System Memory	One 204-pin DDR3L SODIMM Socket Supports Up to 8GB DDR3L 1333 SDRAM	
SSD	One CompactFlash Type I/ II Socket	
Hard Driver Bay	One 2.5" SATA HDD	
Watchdog Timer	H/W Reset, 1sec. ~ 65535sec./1sec.step	
H/W Status Monitor	Monitoring system temperature, voltage, and cooling fan status. Auto throttling control when CPU overheats	
Expansion	1 x mPCIe with SIM Slot, 1 x mPCIe Supports mSATA	
Rear I/O 		
Serial Port	1 x RS-232	
Ethernet	1 x RJ-45	
USB	3 x USB 2.0	
Speaker	2 x 5W	

## SPC-1209/1709

Display 		
Chipset	Intel Bay Trail SoC Integrated Graphics	
Resolution	HDMI 1.4a resolutions up to 1920x1200@ 60 24bpp	
Audio 		
AC97 Codec	Realtek ALC892 supports 5.1-CH Audio	
Ethernet 		
LAN Chip	Intel® I210IT Gigabit LAN, Optional Dual LAN	
Ethernet	10/100/1000 Base-Tx Fast Ethernet compatible	
Mechanical & Environment 		
Color	Front & Rear Panel Silver	
Mounting	Wall/Stand/VESA 75 mm x 75 mm	
Power Requirement	+12 V ~ +26 V	
Power Adapter	Input: 100~240 Vac/ 50~60 Hz Output: +24 Vdc / 2.5 A (60W)	
Power Type	AT/ATX	
Operating Temp.	0 ~ 40°C	
Storage Temp.	-20 ~ 60°C	
Operating Humidity	5%~90% relative humidity, non-condensing	
Demensions	311 x 272 x 58 mm	405 x 353 x 66.6 mm
Weight	4.23 Kgs	7.5 Kgs



### Note:

1. For thermal concern, turbo boost feature of SPC true flat rear case SKUs with INTEL J1900 processor has been turned off in BIOS default setting.
2. Specifications are subject to change without notice.

## 1.4 System Overview

### 1.4.1 SPC-1209 Rear View

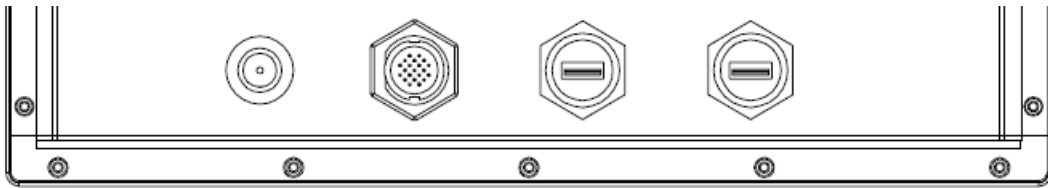

#### Connectors

Label	Function	Note
DC-IN	Waterproof DC Power-in connector	
18pin	Waterproof 18pin connector (Use attached cable to convert 1xUSB/1xLAN/1xCOM)	
USB	Waterproof USB 2.0 connector x 2	

### 1.4.2 SPC-1709 Rear View

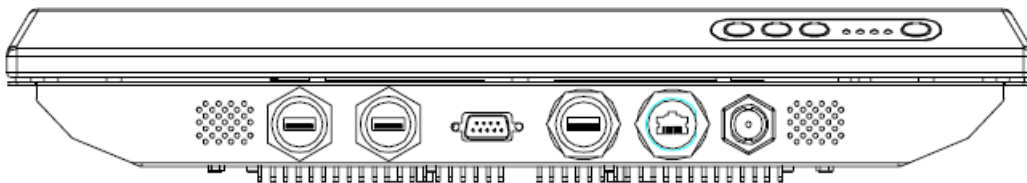

#### Connectors

Label	Function	Note
Membrane	Power & 3 programmable buttons	
USB	Waterproof USB 2.0 connector x 3	
COM	Waterproof DB-9 connector	
LAN	Waterproof RJ-45 connector	
DC-IN	Waterproof DC Power-in connector	

## 1.5 System Dimensions

### 1.5.1 SPC-1209 Front, rear and side view

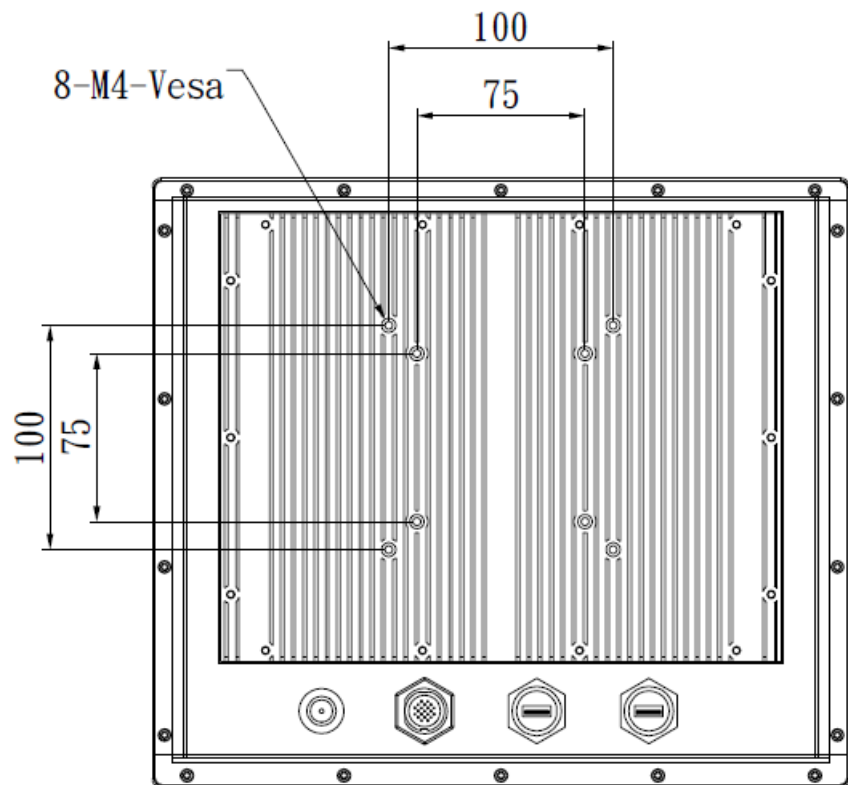
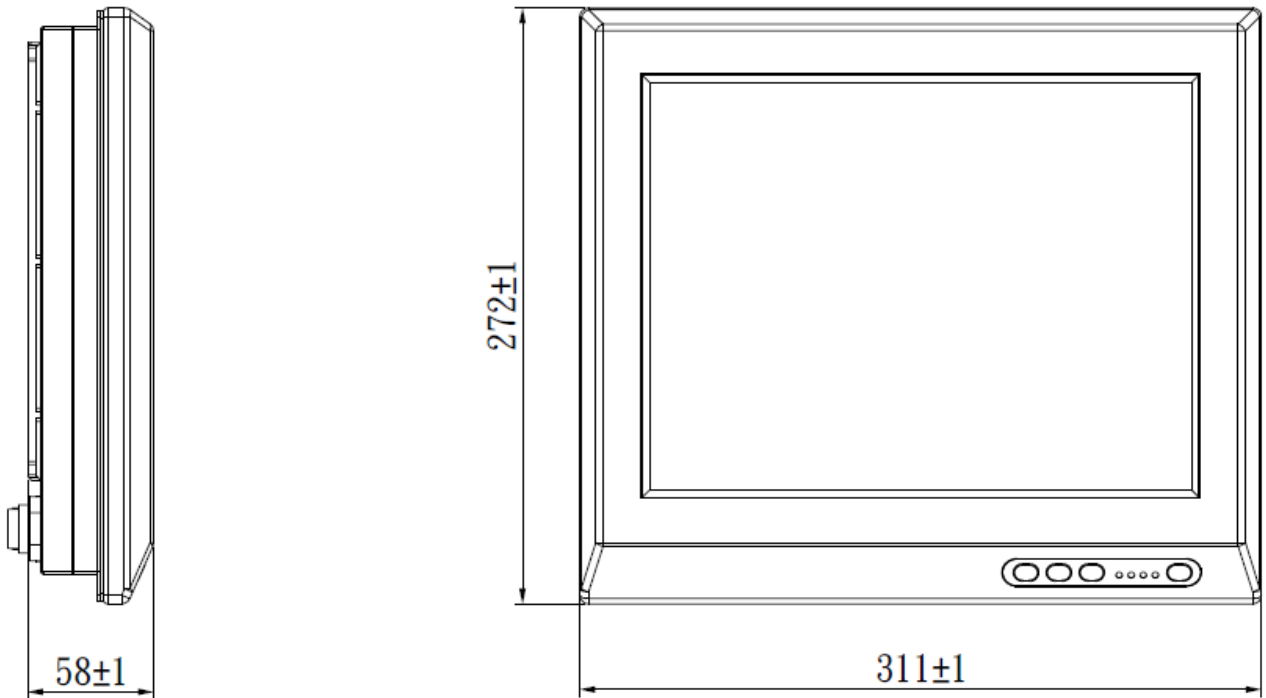

(Unit: mm)



1.5.2 SPC-1709 Front, rear and side view

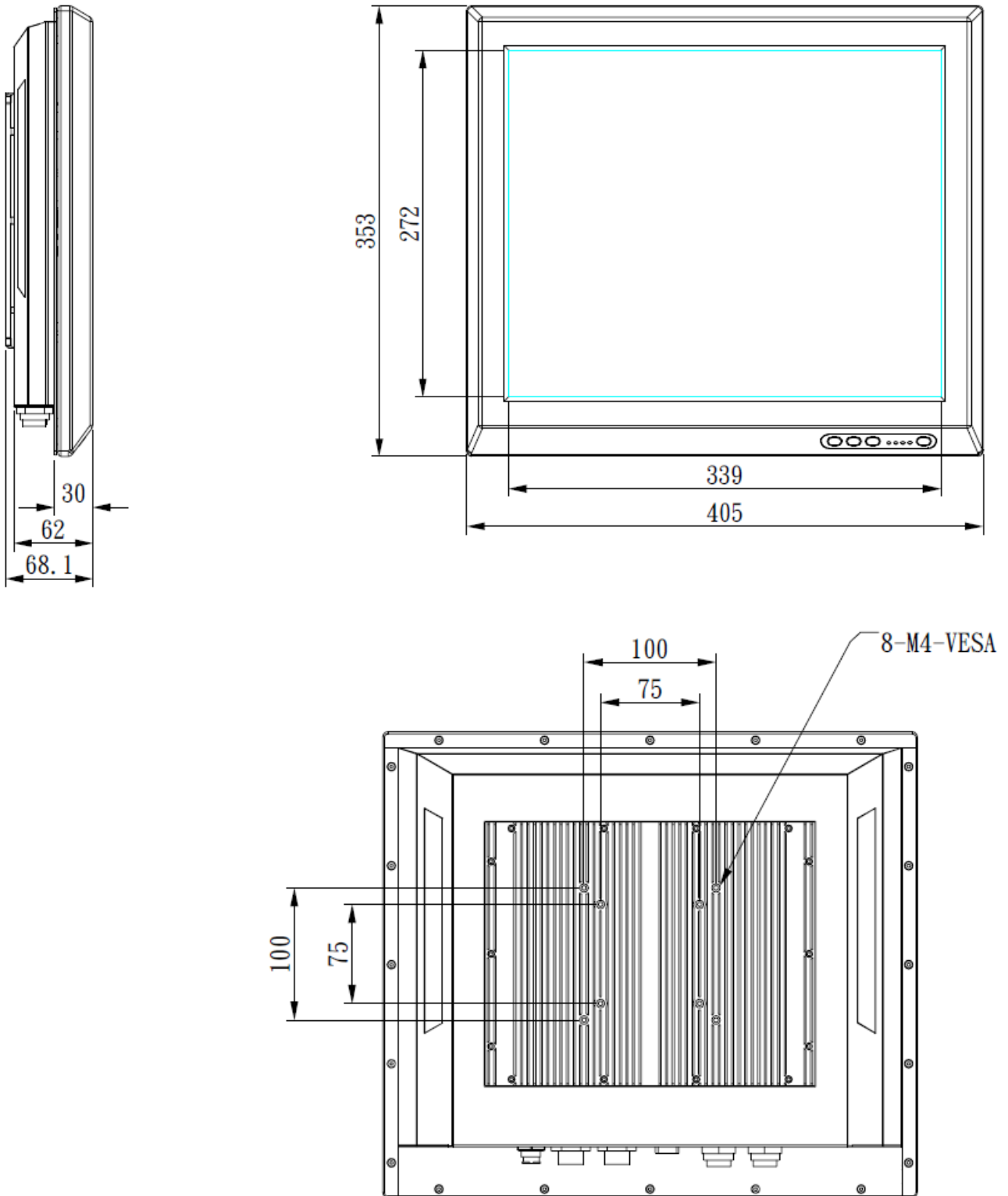

(Unit: mm)

# 2. Hardware Configuration

---

For advanced information, please refer to:

- 1- EBM-BYT User's Manual



**Note:** If you need more information, please visit our website:

<http://www.avalue.com.tw>

## 2.1 SPC-1209/1709 connector mapping

### 2.1.1 Waterproof DB-9 connector (COM)

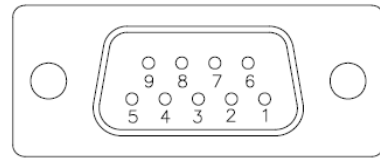
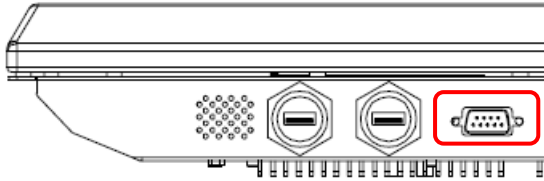

Signal	PIN	PIN	Signal
NDCDA#_485TXN	1	6	NDSRA#
NRXDA_485TXP	2	7	NRTSA#
NTXDA_485RXP	3	8	NCTSA#
NDTRA#_485RXN	4	9	NRIA#
GND	5		

